

Custom Rugged Enclosure

VEGA 2052



Key Features

- Tough, Rugged, Vandal-resistant Housing, IK10 & IP66 – Marine Grade
- PoE (802.3af) or 12VDC
- Super Low-Light Performance
- 2MP, 2.7~13.5mm Motorised Zoom Lens with Smart Auto Focus
- Easy Positioning
- ONVIF Profile S, G & T Compliant
- 60m Adaptive IR Integral LEDs
- Intelligent Video Analytics
- Audio In/ Out
- Fully Cable-managed Solution, Keeps Cables Hidden and Secure
- Adjustable Sun and Rain Visor

VEGA 2052 Camera

The VEGA 2052 camera is part of the VEGA housing range. The 2MP camera utilises leading-edge sensor technology, with a Super low-light CMOS sensor for high-quality images in daytime or night-time settings. PoE power means simple plug and play experience, with low power consumption (12W, IR on). A motorised Zoom lens with Auto Focus system ensures crisp, clear images all the time. A tough, stylish housing completes the high-quality offering.

Adaptive IR Illumination

Integral IR LEDs provide up to 60m of Adaptive IR range, ensuring any night-time activity is captured in full HD with stunning image quality. The VEGA 2052 automatically adjusts the IR intensity in proportion to zoom and scene content. The IR LEDs are fully isolated from the camera lens, meaning no glare or haze, only crystal-clear images all night long.

Cable Managed Housing

The VEGA 2052 is fully cable-managed, offering bracket base and 20mm conduit access; with two internal 20mm cable glands for enhanced security. Cables can be terminated inside the camera housing itself, so no additional junction box is required. Installation is simplified and the risk of damage from malicious attack, moisture, corrosion or dust is reduced.

Motorised Zoom

A fully motorised 2.7mm ~ 13.5mm Smart Auto Focus lens guarantees sharp images in both day and night-time, whilst making installation setup quick and easy.

Aluminium body, marine grade

A tough, solid die-cast aluminium housing is pretreated and powder coated, resulting in cameras being well-protected against the elements and local environment, to IP66 standard. Rugged IK10 standard housing with an optional Polycarbonate window means your cameras are secure whilst keeping your premises secure.

SD Card Recording

Built-in SD Card recording up to 1TB allows network edge-recording, making sure nothing is missed, even in the event of a network data outage. ONVIF Profile G compliance means the camera can work with a compatible VMS platform or NVR, to automatically interrogate and recover recorded footage as soon as the network connection is restored.

ONVIF Compliant

ONVIF Profile S, G and T compliance offers compatibility with countless VMS platforms and NVRs. A H.265 streaming option means high-quality images at lower network bandwidth and hard-disk storage.

Additional Features

Motion Detection, Intelligent Video Analytics, Smart Encoding and Region of Interest allow users to tailor cameras to suit each individual scene, optimising recording time for only events or information that really matters to you.

Simple Installation, maintenance free

3D positioning arm allows you to find that perfect spot to view exactly what you need. An adjustable visor means unwanted glare is kept out in almost any installation positions.

The housing is symmetrical, allowing for pendant or pedestal mounting to ceilings, walls and soffits.

Custom RAL Colour Options

The VEGA 2052 rugged camera housing range is available in light grey (RAL 7035) as standard. However, the cameras can also be ordered in any matt or gloss RAL colour. Customers simply specify the colour they require and all the VEGA 2052 camera's external parts are painted to order. The powder-coat paint gives a robust, UV light-stable finish.

	<p>VEGA-2052-WALL: Fully cable managed camera, including wall bracket; 12V DC/ POE, 2MP Sony Exmor lowlight sensor, 2.7-13.5mm motorised lens and autofocus. Ruggedised marine finish.</p>
	<p>VEGA-2052-PED: Fully cable managed camera, including pedestal bracket; 12V DC/ POE, 2MP Sony Exmor lowlight sensor, 2.7-13.5mm motorised lens and autofocus. Ruggedised marine finish.</p>
<p>Options</p>	<p>VEGA-CUSTOM-PAINT: Custom paint – must specify RAL colour</p>
	<p>RVX2-POLE-G: Pole mount adaptor 60-90mm for RVX2-WALL - Light Grey</p> <p>RVX2-POLE-B: Pole mount adaptor 60-90mm for RVX2-WALL - Black</p> <p><i>*Note: Pole mount adaptor interfaces with WALL version of VEGA</i></p>
	<p>RVX2-CNR-G: Corner Mount adapter for RVX2-WALL - Light Grey</p> <p>RVX2-CNR-B: Corner Mount adapter for RVX2-WALL - Black</p> <p><i>*Note: Corner mount adaptor interfaces with WALL version of VEGA</i></p>

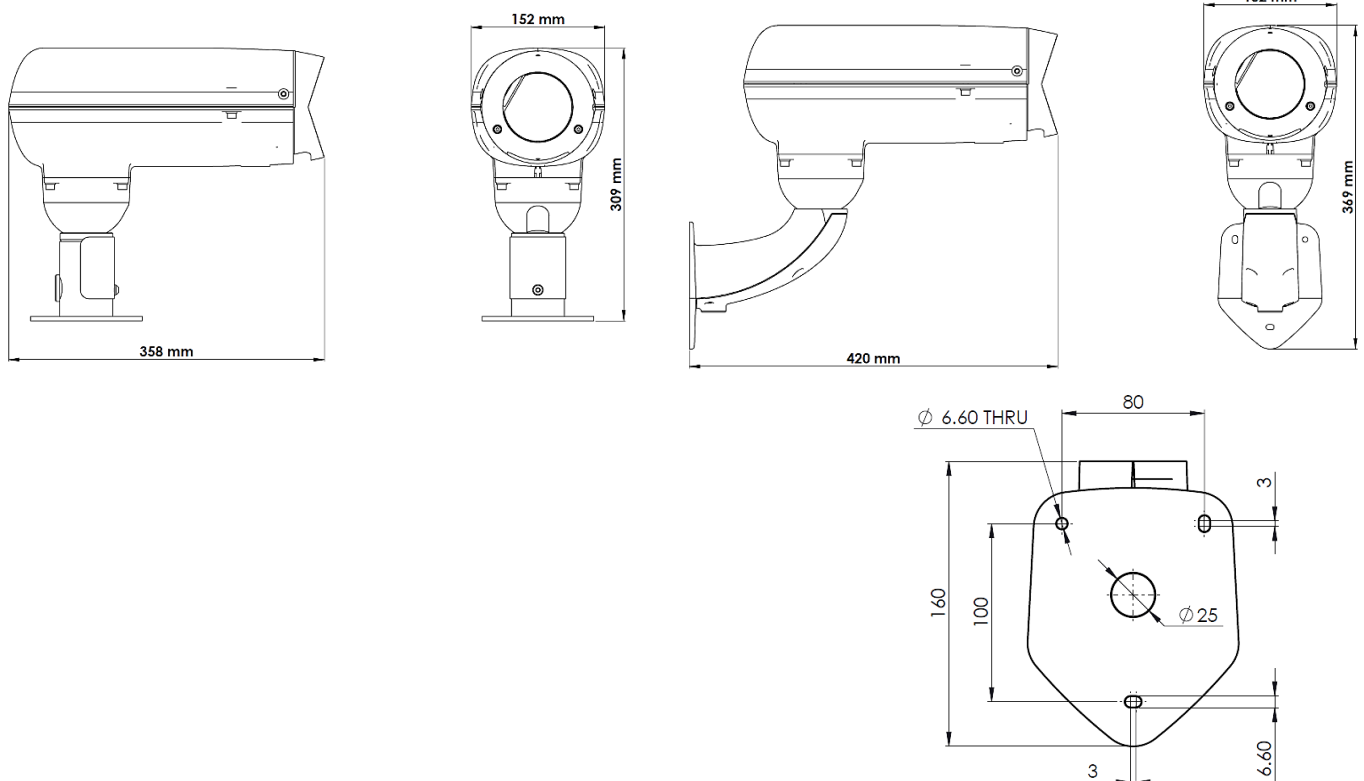

Camera Specification

Camera module	2MP 1/2.8" CMOS Super Low-Light sensor, Progressive-Scan
Sensitivity	Colour: 0.01Lux @ F1.6, AGC ON Monochrome: 0 Lux IR ON
Max. Resolution	1920x1080
S/N Ratio	55dB
Lens	2.7mm~13.5mm Motorised Smart AF F1.3
FoV	H: 101°(W) ~ 28°(T) V: 54° (W) ~ 16° (T)
Noise Reduction	2D/3D Digital
WDR	120dB
Image Enhancement	WDR, BLC, HLC, Defog
IR Range	Up to 60m
Day/Night Switching	True-ICR

Video Streaming

Video Compression	H.265, H.264, MJPEG
Streams	3 + Service Stream
Resolutions	Stream 1: 1920 x 1080, up to 30fps, 1280 x 720 up to 30fps Stream 2: D1, VGA, 640 x 360, CIF, QVGA, up to 30fps Stream 3: VGA, CIF, QVGA, up to 30fps
RTSP Video FPS	RFC2326, Supports VLC & QuickTime 30fps max.
Bitrate	Stream 1: 200kbps ~ 12Mbps Stream 2: 100kbps ~ 6Mbps Stream 3: 100kbps ~ 3Mbps
Smart Encoding	Yes
Streaming Method	Unicast

Network Interface

Interface	Ethernet RJ45, 10-100 Base-T connection
Supported Protocols	IPv4/IPv6, 802.1x, HTTP, HTTPS, TCP/IP, UDP/IP, RTSP, DHCP, NTP, RTCP/RTP, PPPoE, SMTP, DNS, UPnP, FTP, ARP, SNMP, TLS/SSL
Languages (Web interface)	English, Polish, Italian, Portuguese, Spanish, Russian, French, Czech, Hungarian.
ONVIF	Profile S, G, T
Edge Storage (optional)	Up to 256GB
Security	Base-64 authentication, HTTPS (SSL), 802.1x, IP Address Filtering
SDK	Available
Max. Simultaneous Users	10

Events

Alarm I/O	1 in, 1 out
Video Analysis	Motion Detection, Multiple IVA
Email notifications	Yes
Intelligent Analytics	Intrusion, Single line crossing, Double line crossing, Loitering, Wrong way, People counting. Support alarm triggering by specified target types (human and vehicle)
FTP upload	Yes, video or static image
SD recording	Yes, stream selectable
System event notification	SD card, Network interface
Mobile App	Android, IOS, with push events

Audio

Codecs	G.711 ALAW, G.711 ULAW, RAW_PCM
Bit rate	8kbps, 16kbps, 64kbps
Codecs	G.711 ALAW, G.711 ULAW, RAW_PCM

Electrical & Physical

Power Supply	12VDC, PoE (802.3af)
Power Consumption	12W max. (IR On), 4W (IR OFF)
External Dimensions (Excluding mounting bracket)	L 358mm x W 152mm x H 134mm
Weight	Approx. 5kg including mounting bracket
Operating Temperature	-40°C ~ +70°C
Relative Humidity	≤95%, non-condensing
Ingress Protection	IP66
Impact Rating	IK10
Window Material	Polycarbonate
Housing Material	Aluminium
Corrosion Testing	BS EN ISO 9227:2022 1000 Hours Salt Spray
Colour	RAL 7035 Light Grey as standard, any RAL colour by special request
Certifications	CE/FCC